

State of Hawaii  
DEPARTMENT OF LAND AND NATURAL RESOURCES  
ENGINEERING DIVISION  
1151 Punchbowl Street, Room 221  
Honolulu, Hawaii 96813

**ADDENDUM NO. 1**

TO

Job No. J00AO99B  
DLNR Human Resources Office Improvements  
Kalanimoku Building, Room 231  
Honolulu, Oahu, Hawaii

May 21, 2024

This addendum as issued shall become part of the Contract Documents for the subject project. The bid documents, plans, and specifications shall be amended as follows:

**SPECIFICATIONS**

1. The Notice to Bidders page of the Specifications has been revised to include a second site visit on May 24, 2024 at 10:00 A.M.

**PLANS**

1. Sheet A-6 – Revised contact information in the Finish / Material Schedule.

**GENERAL INFORMATION**

1. A voluntary pre-bid conference and site visit was held on May 17, 2024 at 2:00 P.M at the Project Site located in Kalanimoku Building, Room 231. The pre-bid conference agenda and sign-in sheet are attached for information only.

Engineering Division



---

Carty S. Chang  
Chief Engineer

NOTICE TO BIDDERS  
(Chapter 103D, HRS)

COMPETITIVE BIDS for Job No. **J00AO99B, DLNR Human Resources Office Improvements**, Honolulu, Oahu, Hawaii shall be submitted to the Department of Land and Natural Resources, Engineering Division on the specified date and time through the Hawaii State e-Procurement (HIePRO). HIePRO is accessible through the State Procurement Office website at [www.spo.hawaii.gov](http://www.spo.hawaii.gov).

The Department of Land and Natural Resources Interim General Condition, dated October 1994, as amended, and the General Conditions –AG008, latest revision shall be made part of the specifications.

The project is located at Kalanimoku Building Room 231, 1151 Punchbowl Street Honolulu, Oahu, Hawaii.

The work shall generally consist of replacement of flooring and wall base, in the human resources office on the second floor level of the Kalanimoku building. In addition, abatement of hazardous materials, testing and monitoring will be required during removal work. Repainting of existing wall base, remove and dispose existing hardwood service counters / security entry door, six new modular workstations, temporary relocation of office furniture prior to flooring work and reinstallation of office furniture, and installation of new door within the existing entry hallway. Fire alarm work and minor electrical work within the existing hall is in the scope of work.

To be eligible to submit a bid, the Bidder must possess a valid State of Hawaii Contractor’s license classification “B”.

A voluntary pre-bid conference and site visit will be held at the project site, on the second floor Makai Breezeway near room 231 on May 17, 2024 at 2:00 pm. A second site visit will be held at the project site on May 24, 2024 at 10:00 am. In order to protect public health and safety, interested bidders must wear a mask and follow social distancing practices by maintaining a distance of 6 feet from each other.

The estimated cost of construction is \$350,000.00.

The award of the contract, if it be awarded, will be subject to the availability of funds.

Since the estimated value of the cost of construction is more than \$250,000, the apprenticeship agreement preference pursuant to Hawaii Revised Statutes §103-55.6 (ACT 17, SLH 2009) shall apply.

Should there be any questions, please refer to the HIePRO solicitation.

CAREFULLY REMOVE, STORE, AND REINSTALL GLASS/ PLASTIC SCREENS ON PARTITIONS AT NO ADDITIONAL COST TO THE STATE.

REFER TO SHT A-3 FOR DIMENSIONS.



(E) UNDER HUTCH, 2 EA IN WORKSTATIONS, TYP.

1 EXAMPLE WORKSTATION, TYP. WST-1

REFER TO SHT A-3 FOR DIMENSIONS.



CAREFULLY REMOVE, STORE, AND REINSTALL GLASS/ PLASTIC SCREENS ON PARTITIONS AT NO ADDITIONAL COST TO THE STATE.

(E) UNDER HUTCH, 2 EA IN WORKSTATIONS, TYP.

2 EXAMPLE WORKSTATION, TYP. WST-2

REFER TO SHT A-3 FOR DIMENSIONS.



CAREFULLY REMOVE, STORE, AND REINSTALL GLASS/ PLASTIC SCREENS ON PARTITIONS AT NO ADDITIONAL COST TO THE STATE.

(E) UNDER HUTCH, 2 EA IN WORKSTATIONS, TYP.

3 EXAMPLE WORKSTATION, TYP. WST-3

DOOR TYPE

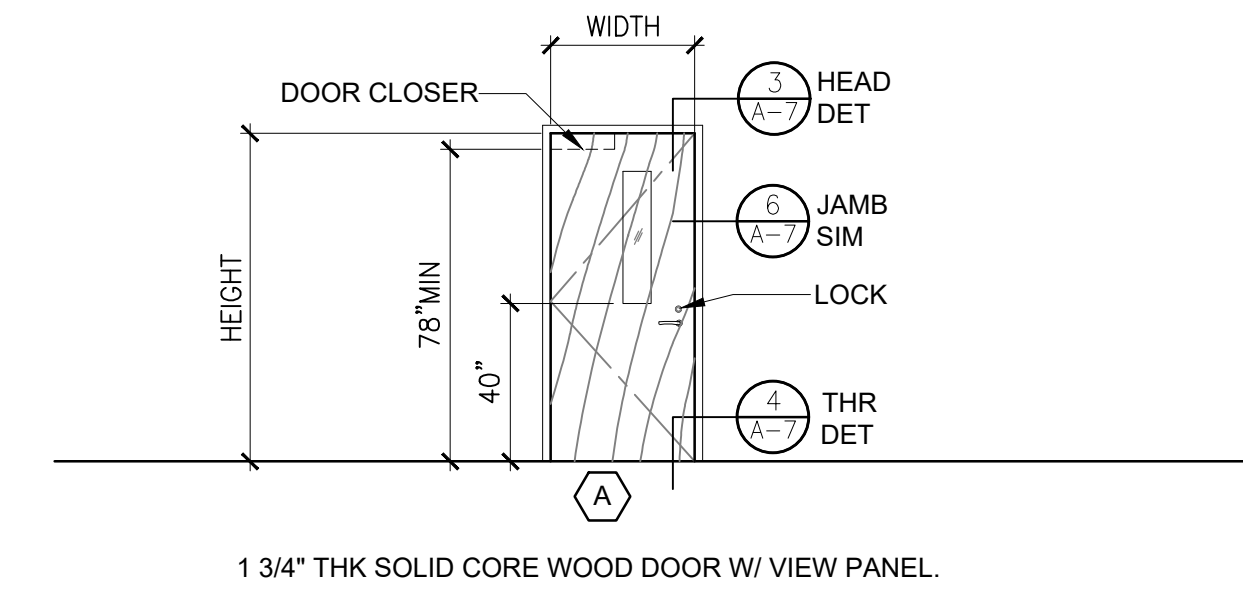

1 3/4" THK SOLID CORE WOOD DOOR W/ VIEW PANEL.

DOOR SCHEDULE

ROOM/ SPACE	DOOR NUMBER	DOOR TYPE	DOOR MATERIAL	DOOR FINISH	WIDTH	HEIGHT	THICKNESS	FRAME			FIRE RATING	HARDWARE GROUP	GLASS	REMARKS
								MATERIAL	FINISH (INT/EXT)	DETAIL				
RM 231 ENTRY	D1	A	SC, FLUSH, WOOD	PAINT, [CS-1]	3'-0"	7'-0"	1-3/4"	PER MFG, METAL	PER MFG	3/A-7 6/A-7 4/A-7	20 MIN	001	CLEAR	- FR W/ LOW -E GLAZING - PAINT TO MATCH EXISTING BUILDING INTERIOR

FINISH / MATERIAL SCHEDULE

TYPE	DESCRIPTION	COLOR	FINISH / PRODUCT INFO.	MANUFACTURER	REMARKS
CPT-1	CARPET BROADLOOM TUFTED - COLORSTRAND NYLON - ADMIN OFFICE	COLLECTIVE STRUCTURE BC638 TWILIGHT - 575	MOHAWK GROUP - LEES (OR APPROVED EQUAL) GLUE-DOWN	MNF: LEES CONTACT: JANCIE DELA CRUZ, MOHAWK GROUP TEL: (808) 829-2095 EMAIL: jancie_delacruz@mohawkind.com	PROVIDE PRODUCT DATA SUBMITTAL SAMPLES AND SHOP DRAWINGS DIAGRAM(S) FOR ARCHITECT REVIEW PRIOR TO ORDER AND INSTALLATION. GLUE-DOWN ADHESIVE APPLICATION/ PRODUCT TO BE SUBMITTED PER MANUFACTURER RECOMMENDATION.
CS-1	PAINT - DOORS	CLEAR STAIN	SEMI-GLOSS	MNF: SHERWIN WILLIAMS CONTACT: RICHARD CONDIE, CSI TEL: (916) 267-3232 EMAIL: richard.condie@sherwin.com	PROVIDE PRODUCT DATA SUBMITTAL AND SAMPLE BRUSH OUTS FOR ARCHITECT REVIEW PRIOR TO ORDER AND INSTALLATION.
PT-1	PAINT - WALL PARTITION, DOOR FRAME	MATCH: EXISTING OFFICE COLOR	SEMI-GLOSS	MNF: SHERWIN WILLIAMS CONTACT: RICHARD CONDIE, CSI TEL: (916) 267-3232 EMAIL: richard.condie@sherwin.com	PROVIDE PRODUCT DATA SUBMITTAL AND SAMPLE BRUSH OUTS FOR ARCHITECT REVIEW PRIOR TO ORDER AND INSTALLATION.
RB-1	RUBBER BASE - COVE BASE	FLAGSTONE R41FS	ARMSTRONG FLOORING (OR APPROVED EQUAL) - 4" RUBBER BASE	MNF: ARMSTRONG FLOORING CONTACT: SHEILA SURBAN, TRI-WEST TEL: (808) 372-0529 EMAIL: ssurban@trivestltd.com	PROVIDE SUBMITTAL AND SAMPLE PRODUCT DATA FOR ARCHITECT REVIEW PRIOR TO ORDER AND INSTALLATION.
RB-2	RUBBER BASE - COVE BASE	MATCH: EXISTING HALLWAY COLOR	ARMSTRONG FLOORING (OR APPROVED EQUAL) - 4" RUBBER BASE	MNF: ARMSTRONG FLOORING CONTACT: SHEILA SURBAN, TRI-WEST TEL: (808) 372-0529 EMAIL: ssurban@trivestltd.com	PROVIDE SUBMITTAL AND SAMPLE PRODUCT DATA FOR ARCHITECT REVIEW PRIOR TO ORDER AND INSTALLATION.
VCT-1	VINYL COMPOSITE TILE PREMIUM EXCELON IMPERIAL TEXTURE - OPEN OFFICE AREA, CONFERENCE RM, RM 231 ENTRY	STERLING 51904	ARMSTRONG FLOORING (OR APPROVED EQUAL) 12" X 12" POLISHED, SEE REMARKS.	MNF: ARMSTRONG FLOORING OR APPROVED EQUAL CONTACT: SHEILA SURBAN, TRI-WEST TEL: (808) 372-0529 EMAIL: ssurban@trivestltd.com	PROVIDE SUBMITTAL AND SAMPLE PRODUCT DATA FOR ARCHITECT REVIEW PRIOR TO ORDER AND INSTALLATION. FLOOR POLISH S-480 OVER NEW TILE. PROCEED WITH INSTALLATION ONLY AFTER SUBSTRATES PASS MOISTURE TESTING ACCORDING TO FLOOR TILE MANUFACTURER'S WRITTEN RECOMMENDATIONS.

FURNITURE SCHEDULE

TYPE	QUANTITY	DESCRIPTION	COLOR	PRODUCT INFO.	MANUFACTURER	REMARKS
WS-1	6	L-SHAPED WORKSTATION MODEL: HWV93AALP SERIES: SYSTEMS (ABOUND)	DESK: COGN.COGN.P PANELS: MATCH EXISTING PANEL FABRIC COLOR	72 X 36 X 24 X 24 LEFT CORNER COVE WORKSURFACE EDGE BAND	HON (OR APPROVED EQUAL)	PROVIDE SUBMITTAL PRODUCT DATA AND MANUFACTURER FINISHES FOR ARCHITECT REVIEW PRIOR TO ORDER AND INSTALLATION. CONTRACTOR TO CONDUCT SITE VISIT TO VERIFY BASIS OF DESIGN L-SHAPED WORKSTATION, POWER REQ. TO MATCH EXISTING, PRIOR TO PROVIDING SHOP DRAWINGS AND PRODUCT INFO.

REVISION NO.	SYM	DESCRIPTION	SHT./OF	DATE	APPROVED
		ADDENDUM NO. 1		5/17/2024	
STATE OF HAWAII DEPARTMENT OF LAND AND NATURAL RESOURCES ENGINEERING DIVISION					
DLNR HUMAN RESOURCES OFFICE IMPROVEMENTS KALANIMOKU BUILDING, ROOM 231					
DOOR TYPE, FINISH MATERIAL SCHEDULE FURNITURE SCHEDULE, PHOTOS					
DESIGNED: RTM		SUBMITTED:			
DRAWN: KH		DATE: 4/12/24			
CHECKED: RTM		SCALE: AS NOTED			
APPROVED:		CHIEF ENGINEER		DATE	
This work was prepared by me or under my supervision and construction of the project will be under my observation. Expiration date 04/30/26.		OMIZU Architecture Inc.		DRAWING NO. A-6	

**Agenda**  
**Pre-Bid Conference**  
**For**  
**Job No. J00AO99B**  
**DLNR Human Resources Office Improvements**  
**Kalanimoku Building, Room 231**  
**Honolulu, Oahu, Hawaii**

Date: May 17, 2024 @ 2:00 pm.

Location: 1151 Punchbowl Street, Room 231, Honolulu, Hawaii

**1. Introductions**

**2. Brief Description of Project and Scope**

The Human Resources Office Improvements project consists of:

- Remove and replace the existing flooring and wall base
- Abatement of hazardous materials, including testing and monitoring are required during removal work
- Temporary relocation and reinstallation of existing furniture prior to flooring work
- Remove and dispose the existing hardwood service counters / security door / frame
- Install new VCT tiles or broadloom carpet as indicated on plans
- Install six (6) new modular workstations
- Install one (1) new door / frame / wall and one (1) fire alarm within the hallway space
- Touch-up paint / repainting for walls / wall base as needed.

Work in the building shall only be allowed on the weekdays between the hours of 7:45 am to 4:45 pm. Abatement work shall only be allowed after business hours or during the weekend.

Bid Opening is on June 3, 2024 at 2:00 p.m. Bids shall be uploaded to HiePRO.

Last day to submit Questions/RFIs is May 23, 2024 at 4:30 p.m.

Meeting agenda and sign-up sheet will be posted on HiePRO.

**3. Questions**

Note: All answers and comments are unofficial, the official answers will be uploaded to HiePRO in an Addendum.

Please make sure your questions are heard and written down to make sure it is included in the Addendum.

**4. Walk Through of Project Area.**

**SIGN-IN SHEET**  
**PRE-BID SITE MEETING**

Job Title: DLNR Human Resources Office Improvements, Kalanimoku Building, Room 231

Job Number: J00AO99B

Date: May 17, 2024

Time: 2:00 P.M.

	NAME	AGENCY/COMPANY	PHONE NO.	EMAIL ADDRESS
1	Frances Constantino	DLNR-ENG	808-587-0279	frances.constantino@hawaii.gov
2	Hillary Miyamoto	DLNR-HR	808-587-0190	hillary.k.miyamoto@hawaii.gov
3	Reid Mizue	Omizu Architecture	808-721-4267	reid@omizuarch.com
4	Kristen Harano	Omizu Architecture	808-589-2020	kristen@omizuarch.com
5	Michelle Taitaka	Starcom Builders	808-952-6048	mmtake@starcombuilders.com
6	Jason Kon	Society Contracting	808-392-7579	bids@societycontracting.com
7	Val Lee	WATTEK	808-292-8765	val@wattetekhawaii.com
8	Valerie Suzuki	DLNR-BNC	808-587-0275	Valerie.s.suzuki@hawaii.gov
9				
10				
11				
12				
13				
14				
15				
16				